

 **D'AVINO**

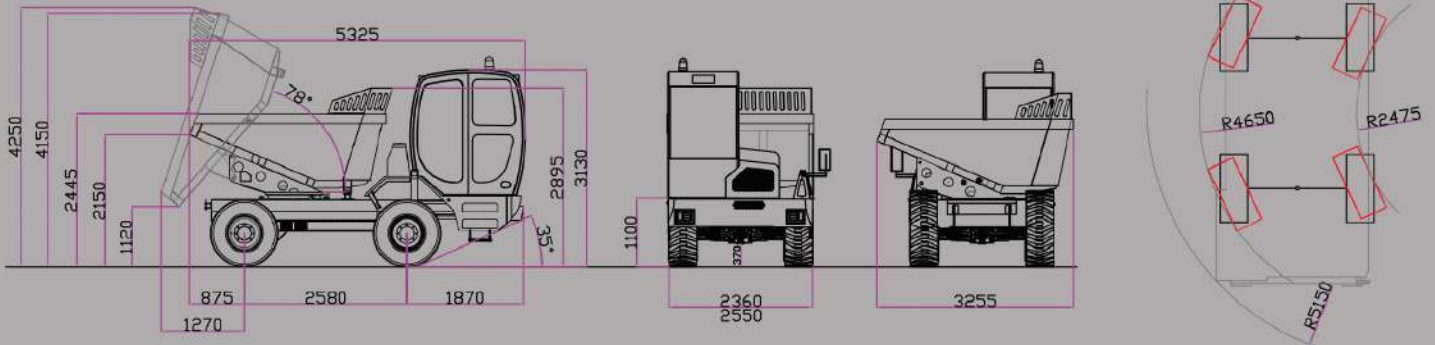

120TW



DESCRIPTION (ISO 7132:2003): Trilateral rear dumping dumper – Rigid frame – N. 2 axles - N.4 wheel steering/drive
Rotating driving seat
Max. load capacity 12.000 kg

ENGINE:

Perkins t 904J-E36TA
EU Stage V/U.S. EPA Tier 4 Final 90 kW (121 hp)

Deutz TCD3.6L04
EU Stage IIIB/U.S. EPA Tier 4i 90 kW (121 hp)

TRANSMISSION: 4x4 full wheel drive - 4 speeds forward/reverse (2 hydraulic, 2 mechanic)
Max speed 35 Km/h - Max full loaded gradeability 40%
Hydrostatic “automotive” transmission with variable displacement pump and variable displacement 2 position hydraulic motor controlled by an electro-hydraulic lever for “slow”/“fast” speed and reverse movement selection
Two-speed mechanical gearbox with electro-hydraulic lever control for working gear selection and transfer gear

AXLES: Both load-bearing and steering with planetary reduction gears on the wheel hubs - Front axle oscillating at 8° with differential - Limited Slip – Rear fixed with 100% locking differential and flanged mechanical reducer

BRAKES: Internal oil-bath disc hydraulic service brake acting on both axles activated by a double servo pump – Internal oil-bath disc hydraulic parking brake acting directly on rear axle with hydraulic negative type control – Emergency brake incorporated directly in service brake

STEERING: Hydrostatic fed by an independent pump Four wheel steering by means of 2 double action cylinders
Hydraulic steering selector device for 3-ways steering
hydraulic selection device of three types of steering with electro-hydraulic - control at the driver's seat for front wheel drive/ 4 wheel bi-lateral drive/ 4 wheel parallel drive (crab mode)

DUMP BODY: Reinforced dump body with tilting by means of 1 hydraulic Telescopic Cylinder
Struck capacity 4.900 l
SAE heaped capacity 6.000 l

OPERATOR’S TURRET ROTATING: Mounted on ball-bearing swivel ring - Anatomic seat with pneumatic suspension and safety belt - Arm holder right-hand swivel armrest - Steering column in ABS with electronic display and ergonomic user friendly dashboard and control panels – Closed cabin with electric wiper on front glass – Wide visibility during transfer/work phases

HYDRAULIC SYSTEM: 2-elements hydraulic distributor
Gear pump 26Lt @ 1000 RPM for utilities - Gear pump 20Lt @ 1000 RPM for steering and breaks - 16 µm hydraulic filter - Aluminium heat exchanger for hydraulic oil cooling

ELECTRICAL SYSTEM: 12V - Battery AGM 50 Ah (1000 A)

REFUELLING:

Fuel tank	175 l
Total hydraulic system capacity	175 l

TIRES: 18-19,5 16 PR

DIMENSIONS: 2.360 x 3.130 x 5.325

WEIGHT: 7.960 kg

