

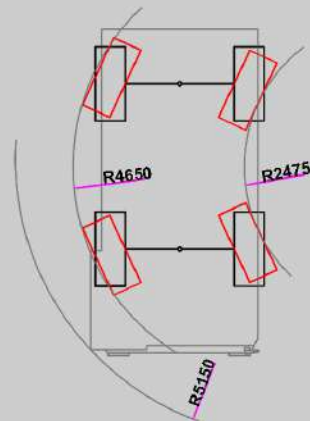

**DI4**

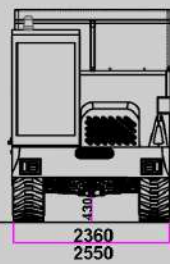

# DI4

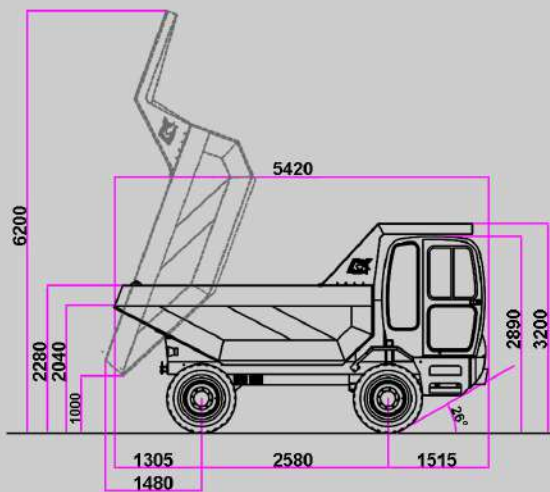

## **DESCRIPTION**

(ISO 7132:2003) Rear dumping dumper N.4 wheel steering/drive – 2 axles Rotating driving seat  
Max. load capacity 14.000 kg

## **ENGINE**

Perkins 904J-E36TA  
EU Stage V/U.S.EPA Tier 4 Final 90 kW (121 hp)  
Perkins 1104D-44TA  
EU Stage IIIA/U.S. EPA Tier 3 83 kW (113 hp)

## **TRANSMISSION**

4x4 full wheel drive, 4 speeds forward/ reverse (2 hydraulic, 2 mechanic) - Max speed 35 Km/h  
Max full loaded gradeability 40% - Hydrostatic “automotive” transmission with variable displacement pump and variable displacement 2 position hydraulic motor controlled by an electro-hydraulic lever for “slow”/“fast” speed and reverse movement selection  
Mechanical gearbox for “work” and “transfer” speed with electro-hydraulic control lever - Inching Pedal

## **AXLES**

Both load-bearing and steering with planetary reduction gears on the wheel hubs – Front axle oscillating at 8° - Rear axle fixed with flanged gearbox

## **BRAKES**

Internal oil-bath disc hydraulic service brake acting on all 4 wheels activated by a dual circuit independent pump – Internal oil-bath disc hydraulic parking brake acting directly on rear axle with hydraulic negative type control – Emergency brake incorporated directly in service brake

## **STEERING**

Hydrostatic fed by an independent pump  
Four wheel steering by means of 2 double action cylinders Steering selector device on operator's console for: front wheel drive/ 4 wheel bi-lateral drive  
4 wheel parallel drive (crab mode)

## **DUMP BODY**

Reinforced dump body with tilting by means of 2 double-acting hydraulic cylinders  
Struck capacity 6.700 l SAE heaped capacity 8.300

## **OPERATOR'S TURRET**

Rotating, mounted on ball-bearing swivel ring  
Anatomic seat with flexible suspension and height adjustment, seat belts - Large high visibility windshield with electric wiper – Steering column in ABS with electronic display and ergonomic user friendly dashboard and control panels - 3-side enclosed ROPS FOBS cabin (optional total closure cab)

## **HYDRAULIC SYSTEM**

1-element hydraulic distributor - Gear pump 26Lt @ 1000 RPM for utilities - Gear pump 20Lt @ 1000 RPM for steering and breaks - 16 µm hydraulic filter  
Aluminium heat exchanger for hydraulic oil cooling

## **ELECTRICAL SYSTEM**

Starter 12V- 3 kW  
Alternator 12V 95A with regulator incorporated  
Battery 12V 110Ah (900A)

## **SERVICE REFILL CAPACITIES**

Fuel tank	175 l
Total hydraulic system capacity	175 l
Engine oil	9,5 l
Engine cooling liquid	7,0 l

## **TIRES**

18 -19,5 16 PR16 PR

## **DIMENSIONS**

2.360 x 5.400 x 2.820 mm

## **WEIGHT**

6170 kg

## **MEETS**

CEE road standards

# **ROCK YOUR BUSINESS**

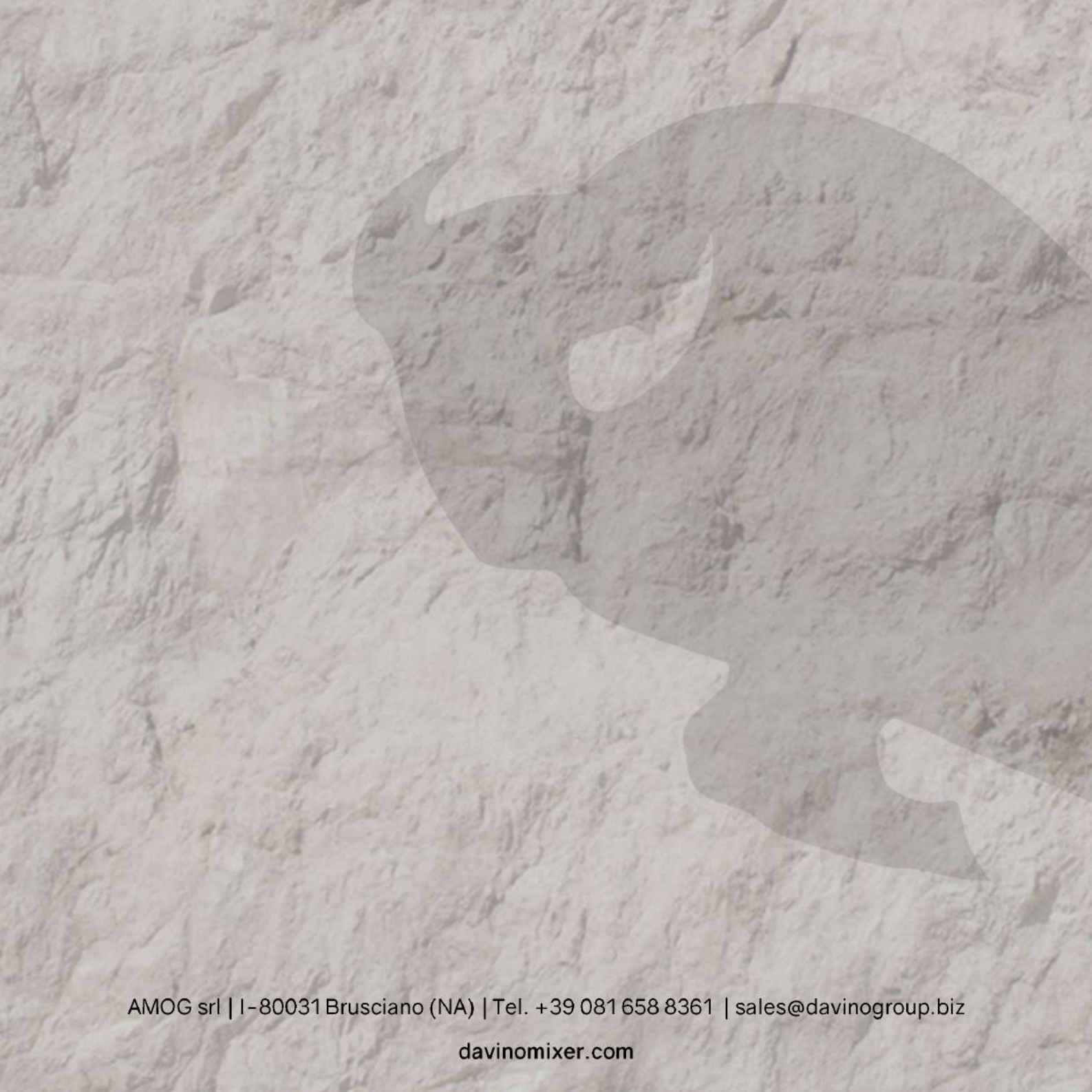

AMOG srl | I-80031 Brusciano (NA) | Tel. +39 081 658 8361 | [sales@davinogroup.biz](mailto:sales@davinogroup.biz)

[davinomixer.com](http://davinomixer.com)